

DATE	BY	REVISION RECORD	EDW	JR	CK

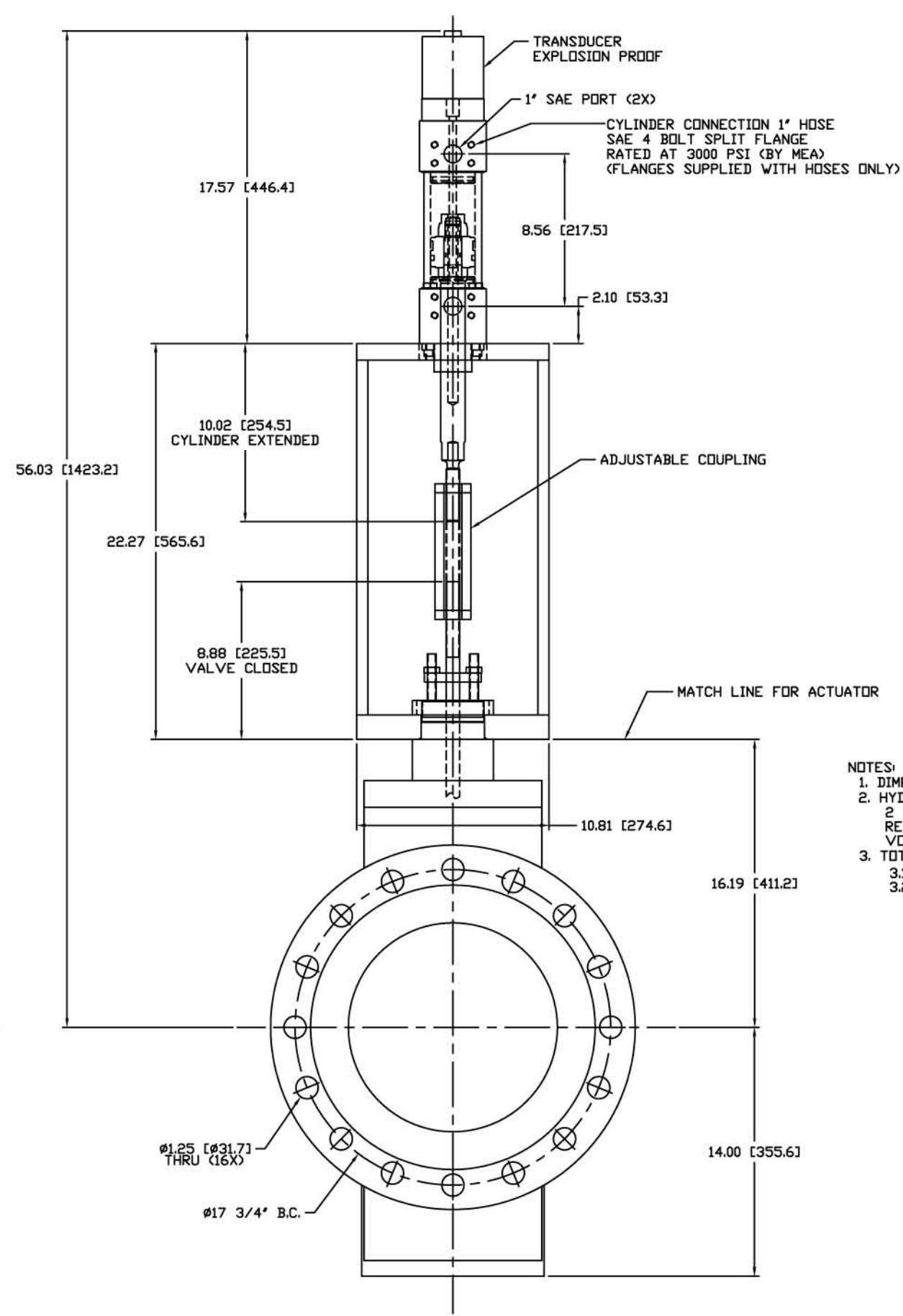
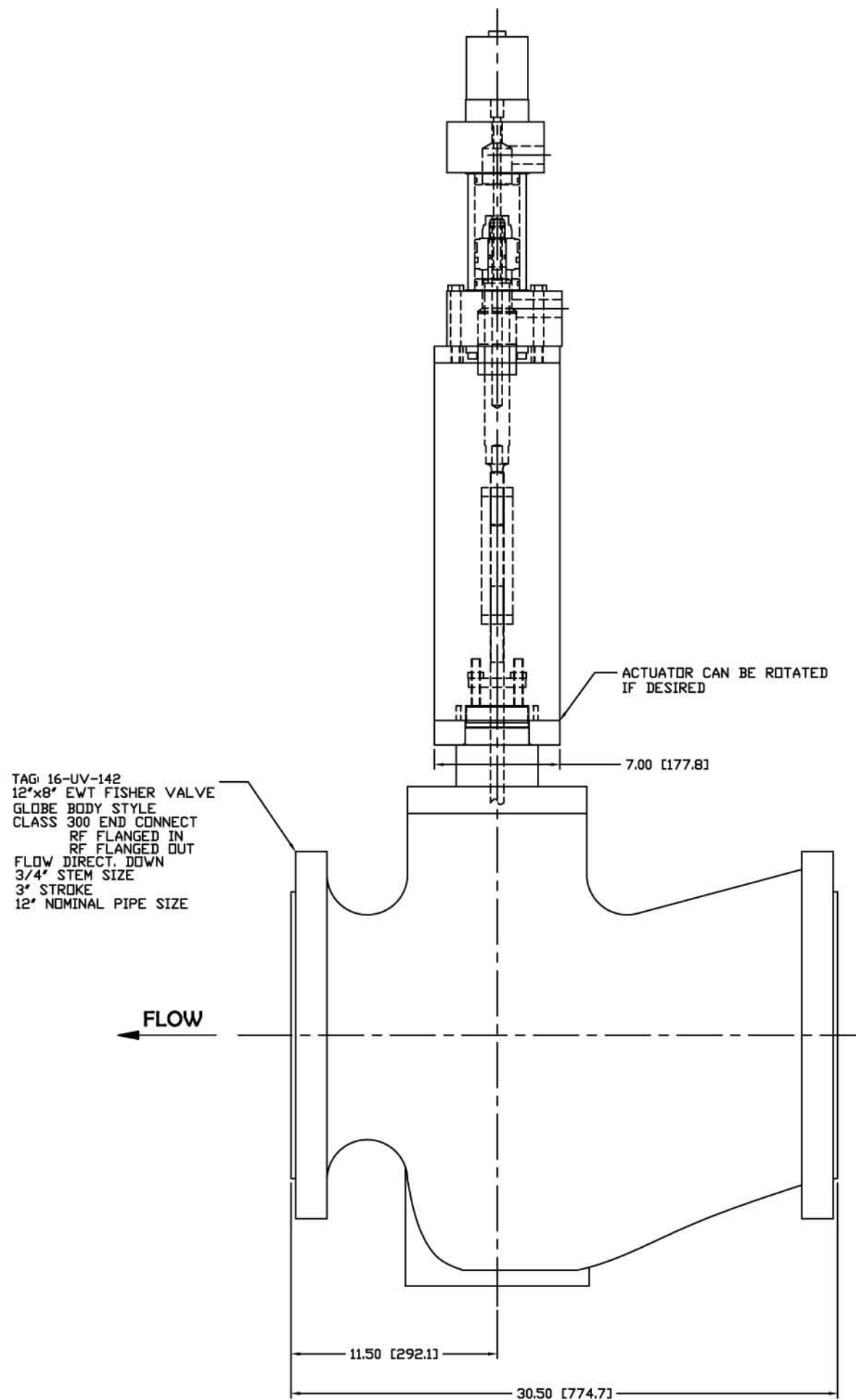

- NOTES:
1. DIMENSIONS IN INCHES [MILLIMETERS].
 2. HYDRAULIC CYLINDER:
2 1/2" BORE x 1 3/8" DIA. PISTON ROD x 3 1/2" STROKE
REQUIRED STROKE TO OPEN THE VALVE - 3" [76.2]
VOLUME FOR 3" [76.2] STROKE - 14.7 CU. IN. (0.3 LITER)
 3. TOTAL WEIGHT: 1590 LBS. (721.9 KG)
3.1. ACTUATOR AND CYLINDER: APPROX. 150 LBS. (68.1 KG.)
3.2. 12" x 8" EWT FISHER VALVE: 1440 LBS (653.7 KG)

THIS IS AN AUTOCAD-12 DRAWING. DO NOT REVISE MANUALLY. CAB FILE # 10468D

		THIS DRAWING IS THE PROPERTY OF MEA, INC. IT IS LOANED WITH THE UNDERSTANDING THAT IT MAY NOT BE REPRODUCED NOR MAY THE INFORMATION CONTAINED HEREIN BE USED FOR THE MAKING OF DRAWINGS OR FOR MANUFACTURING PURPOSES WITHOUT THE WRITTEN CONSENT OF MEA, INC.	
TOLERANCES UNLESS AS NOTED	±N/A	SCALE	1:4
DRAWN BY	CC	CK	BG
APPROVED BY		BG	
TITLE: 16-UV-142 SECOND STAGE VALVE AND ACTUATOR OUTLINE			
DATE	8/1/05	DRAWING NUMBER	D12417-505
REV.	D		